

CAD FILE:

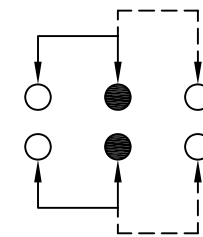

SCHEMATIC (NON-SHORTING)

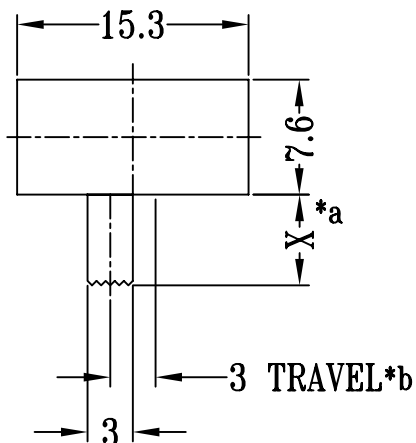
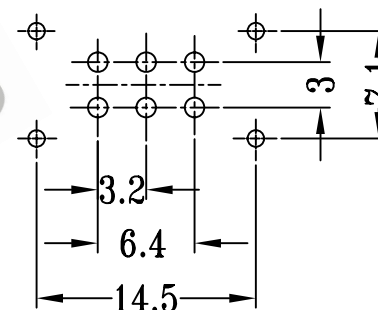
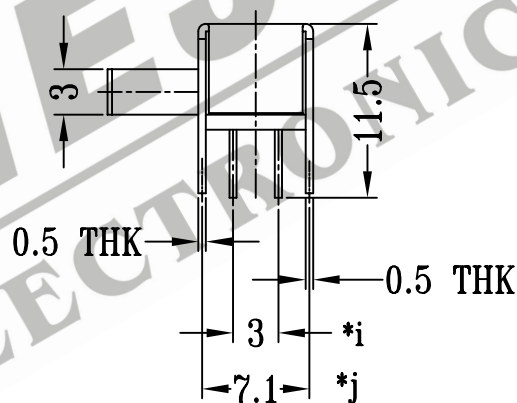
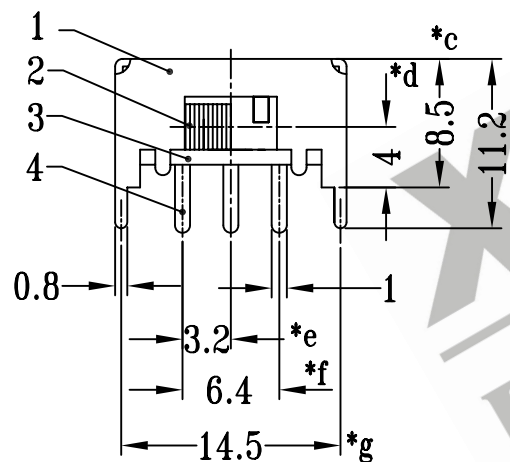

P.C.B LAYOUT

注:带"\*"表示关键尺寸(10个)

NO.	PART NAME	MATERIAL	Q'TY	FINISHING	TOLERANCE UNLESS SPECIFIED	SHENZHEN XIEJIA ELECTRONICS CO.,LTD.						
8						ISSUE	DATE	DESCRIPTIONS	APPD.			
7	STEEL BALL	STEEL	1	NATURAL	WITHIN: 1.5±0.1mm OVER : 1.5±0.2mm	TITLE : HORIZONTAL SLIDE SWITCH MODEL: SK-22F11 ALL MATERIALS MUST BE COMPLIANT TO ROHS						
6	SPRING	STEEL WIRE	1	TEMPER	UNIT : MM					DRWG NO.: XJ-DR-SK22F11-00		
5	CONTACT CLIP	PBS STRIP	2	Ag PLATED	SCALE: 2 : 1					DWN.	ZHOUYU	2001-9-2
4	TERMINAL	BRASS STRIP	6	Ag PLATED OVER Ni PLATED	CHK'D					FANGYING	2001-9-2	
3	BASE	PHENOLIC RESIN	1	NATURAL	APPD.					KANGXINAN	2001-9-2	
2	KNOB	POM	1	BLACK								
1	FRAME	STEEL STRIP	1	Ni PLATED								